

THIS DRAWING IS UNPUBLISHED. RELEASED FOR PUBLICATION  
 © COPYRIGHT BY TYCO ELECTRONICS CORPORATION. ALL RIGHTS RESERVED.

DESIGNED FOR USE WITH  
 RG-55/U, 142, 223 & 400  
 FLEXIBLE CABLES  
 CABLE ENTRY DIAMETER  
 MINIMUM

CONTACT	.040
HOUSING	.121

LOC		DIST		REVISIONS			
P	LTR	DESCRIPTION	DATE	DWN	APVD		
	B	REV PER ECO 07-004710	3/9/2007	DW	KW		

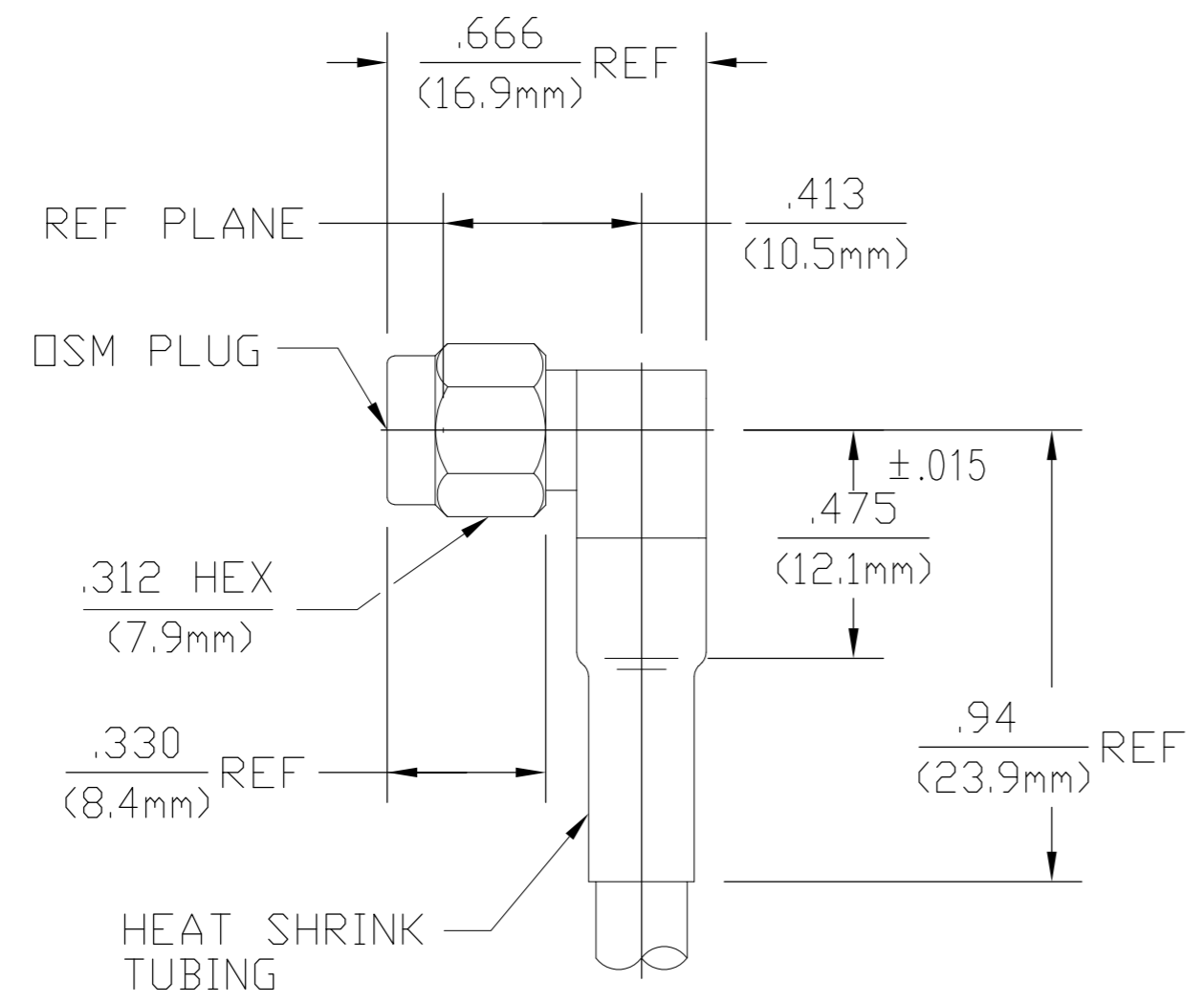

1052072-1  
 PART  
 NUMBER

ELECTRICAL	MECHANICAL	ENVIRONMENTAL
Nominal Impedance (Ohms) 50	Interface Dimensions MIL-STD-348, Fig. 310.1	Temperature Rating -65°C TO 125°C
Frequency Range (GHz) Max operating frequency of cable per MIL-C-17	Recommended Mating Torque 7 to 10 Inch-Pounds	Vibration MIL-STD-202, Method 204, Cond. D
Voltage Rating (VRMS MIN) 335 @ Sea Level	Mating Characteristics: Insertion (MAX Lbs) N/A	Shock MIL-STD-202, Method 213, Cond. I
VSWR 1.15+.02f(GHz)	Withdrawal (MIN Oz) N/A	Thermal shock MIL-STD-202 Method 107, Cond. B except HIGH TEMP SHALL BE 115°C
Insertion Loss(dB MAX) .07 f(GHz)	Force to Engage and Disengage (In/Lbs MAX) 2.0	Moisture Resistance MIL-STD-202, Method 106, except step 7b (vibration) shall be omitted
Rf Leakage (dB MIN) -[60-f(GHz)]	Center Contact Captivation: Axial (Lbs) 6.0	Corrosion MIL-STD-202, Method 101, Cond. B, 5% salt spray
Corona, 70,000 Ft (VRMS MIN) 250 D.W.V.	Radial (Inch-Ounces) 4.0	
(VRMS MIN) 1000 @ Sea Level	Cable Retention: Axial (Lbs) 40 Min(45 Min when used with double braid cable)	
Contact Resistance: Center Contact (Milliohms MAX) 3.0	Torque (Inch Ounces) N/A	
Outer Contact (Milliohms MAX) 2.0	Weight (Grams) 4.8	
Cable To Hsg. (Milliohms MAX) 0.5	Hermetic Seal N/A	
RF High Potential (VRMS MIN @ 5 MHz) 670 @ Sea Level		
I.R. (Megohms Min) 10,000		

COMPONENT	MATERIAL	FINISH
HOUSING COUPLING NUT CAP	STAINLESS STEEL PER ASTM-A484 AND ASTM-A582, TYPE 303	PASSIVATE PER ASTM-A380
DIELECTRIC	TFE FLUOROCARBON PER ASTM-D-1457	N/A
CENTER CONTACT	BERYLLIUM COPPER PER ASTM B 196, ALLOY C17300, CONDITION H OR BRASS PER ASTM-B-16	GOLD PLATE PER MIL-G-45204 OVER NICKEL PLATE PER QQ-N-290
RETAINING RING	BERYLLIUM COPPER PER ASTM B 194, ALLOY C17200, CONDITION H	N/A
GASKET	SILICONE RUBBER PER ZZ-R-765	N/A
SHRINK TUBING	HEAT SHRINKABLE POLYOLEFIN COMPOUND MIL-I-23053/4	N/A
FERRULE	COPPER OR BRASS ALLOY ROCKWELL F65 MAXIMUM	GOLD PLATE PER MIL-G-45204 OVER COPPER PLATE PER MIL-C-14550

THIS DRAWING IS A CONTROLLED DOCUMENT.

DWN JB	2-4-76	 Tyco Electronics Corporation Harrisburg, PA 17105-3608
CHK RMF	2/9/76	
APVD BWC	2-11-76	
PRODUCT SPEC		
APPLICATION SPEC		NAME OSM RIGHT ANGLE CABLE PLUG-CRIMP ATTACHMENT
MATERIAL		SIZE A2
FINISH		CAGE CODE 00779
WEIGHT		DRAWING NO C=1052072
CUSTOMER DRAWING		RESTRICTED TO
SCALE 2:1		SHEET 1 of 1
REV B		